

# Swings - Timber Snake Swing



<b>Code - SNK</b>
<b>Age</b>
5 -12 years
<b>Materials</b>
Laminated Timber
Galvanised Steel
Polypropylene
Rope Seat
Stainless Steel
Chain

<b>Technical Information</b>		
<b>Equipment Dimensions</b>		
Length / Width / Height	4.2m x 2.7m x 3.2m	
<b>Surfacing and Area Required</b>		
Minimum Space Required (L,W,H)	12m x 4.7m x 4.5m	
Max Gradient of Ground	1 in 50	
Free Height of Fall	1.5m	
EN 1176 Impact Area	16m <sup>2</sup>	
Loosefill at 250mm (i.e. Bark / Cushionfall / Sand)	7m <sup>3</sup>	
Grasslok Tiles	25m <sup>2</sup>	
<b>Installation Information</b>	<b>SGF</b>	<b>SF (if different)</b>
Installation Time	2 Person(s) 6 Hour(s)	
Overall Weight	267kg	234kg
Heaviest Part	34kg	
Largest Part	3.0m x 0.13m	
Longest Part	3.5m	
Concrete Required	1.15m <sup>3</sup>	1.21m <sup>3</sup>
Certified to ASTM F1487		

[Click here for more information & downloads](#) 

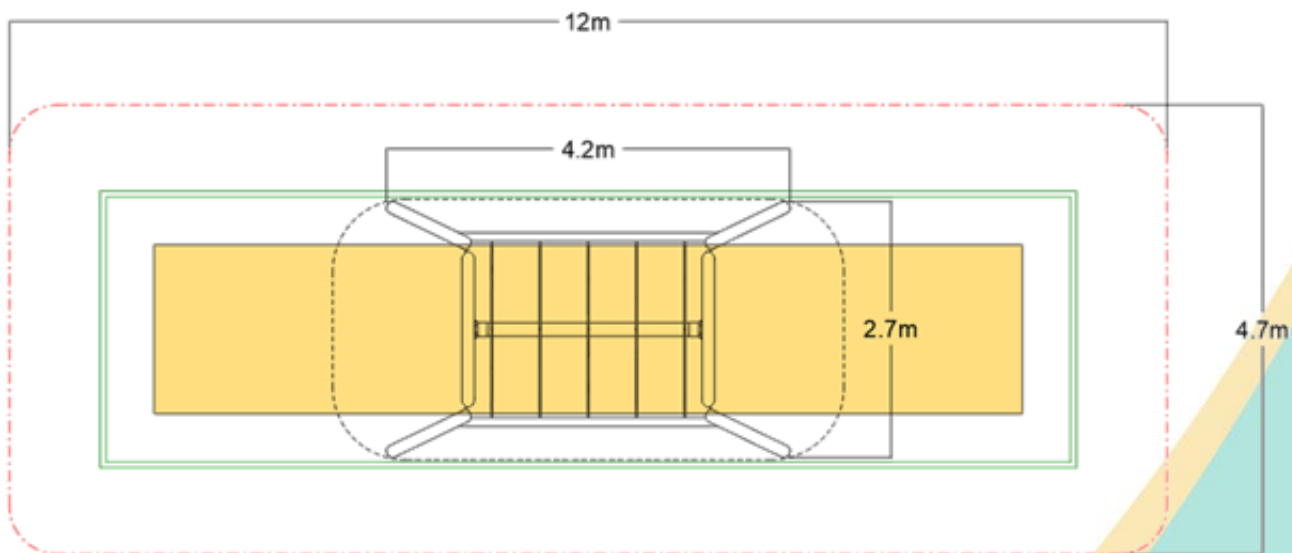
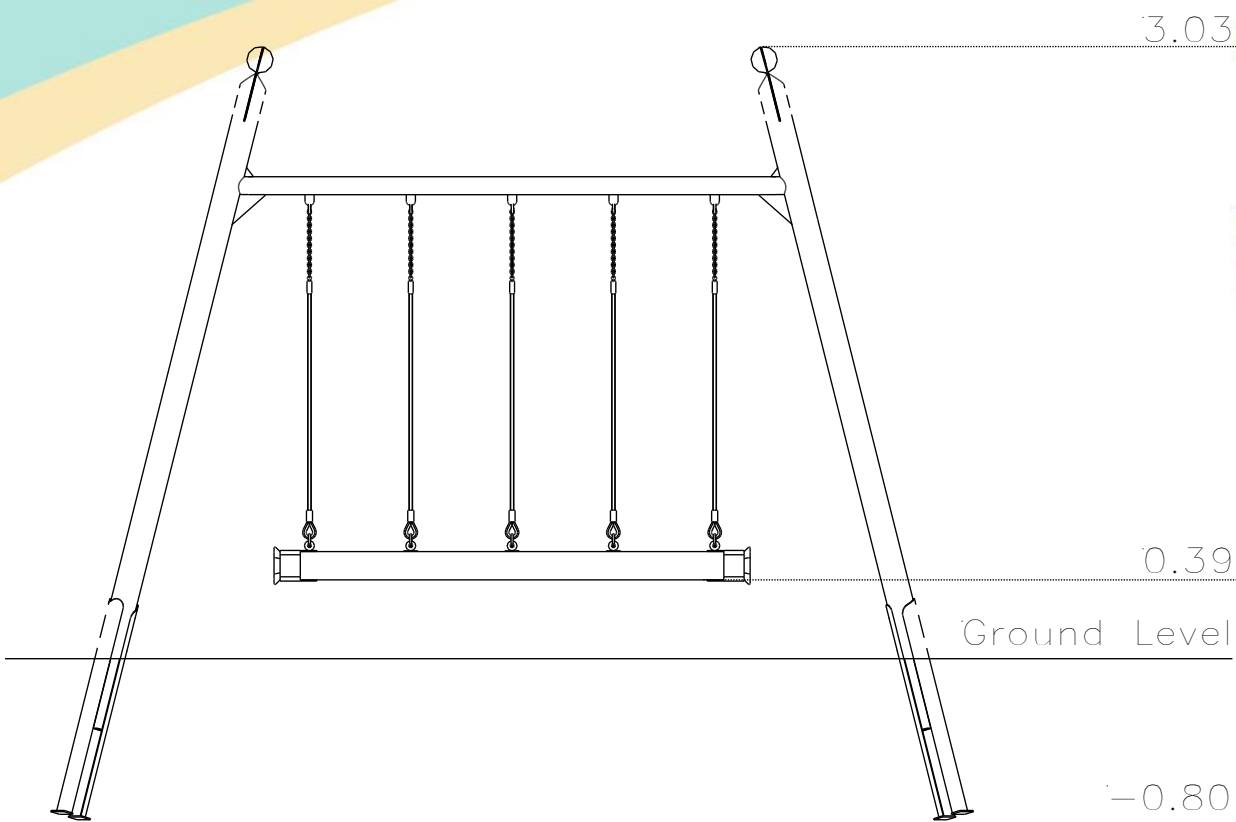

## Circulation Area

-  Loosefill Area
-  Impact Area
-  Free Space
-  Unit Spacing Boundary

[Click here for more information & downloads](#)

