

HIGH PARALLEL BARS

CM3

Designed by athletes for the whole community. These parallel bars have beginner, intermediate and advanced applications to help strengthen arms and core.

Specification

1. 100% Made in Britain
2. Certified to EN16630. All TGO outdoor gym equipment is free from exposed end stops, entrapments, sharp edges and crush points.

ALWAYS ASK FOR EN16630 FOR OUTDOOR GYMS

3. Weatherproof
4. Low maintenance
5. Designs include key elements of Inclusive Fitness Initiative guidelines
6. TGO plant a tree in the NHS Forest for every piece of equipment sold
7. Anti vandal fixings
8. Available in all major RAL colours
9. Paint UV stabilised
10. Welds certified to EN15015614
11. Powder coated finish

Guarantees:

25 years steel work
2 years bearings
5 years paint

[Download Product Files](#)
[Features and Benefits](#)

*Steelwork must not be erected in wind speeds above 5 miles per hour without a construction method statement dealing specifically with the issue of erection in winds above this speed in addition to all other normal contractors and steel erectors construction considerations.



EN
16630



25 YEAR
WARRANTY

**MADE IN
BRITAIN**

HIGH PARALLEL BARS

CM3

Installation

This product is installed 700mm directly into the ground. Please refer to the diagram opposite for safety spacing.

User Height:	1.4m
Users:	2+
Length:	2.1m
Width:	1.5m
Height:	1.43m
Fall Height:	1.2m
Movement Space L:	5.3m
Movement Space W:	4.3m
Safety Space:	23m ²

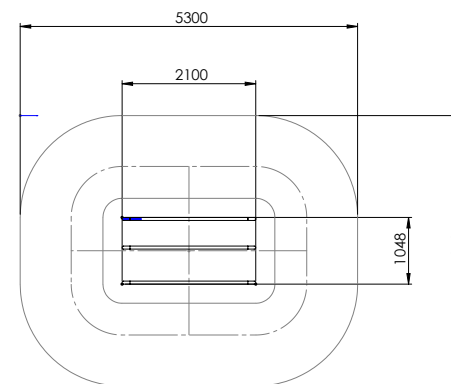

High Parallel Bars

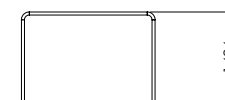

EN
16630



25 YEAR
WARRANTY

MADE IN
BRITAIN