

# Best Mates – Sandbox

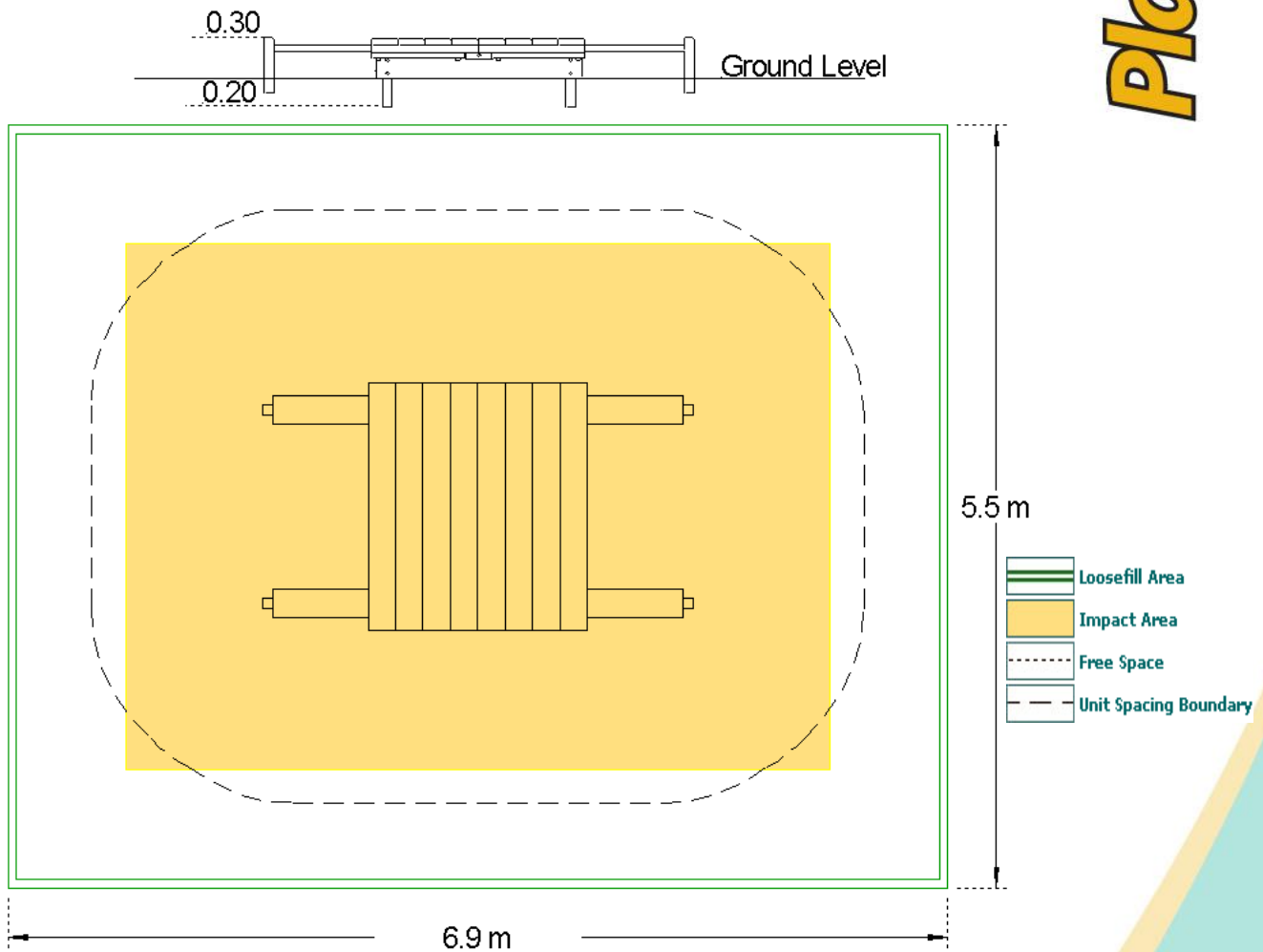

<b>Technical Information</b>	
<b>Equipment Dimensions</b>	
Length / Width / Height	3.0m x 1.8m x 0.3m
<b>Surfacing and Area Required</b>	
Minimum Space Required L/W/H	6.9m x 5.5m x 2.8m
Max Gradient of Ground	1 in 30
Free Height of Fall	0.3m
Impact Area - Wetpour	16.65m <sup>2</sup>
Loosefill at 250mm	4m <sup>3</sup>
Bark / Cushionfall / Sand	
1m x 1m Rubber Tiles	n/a
<b>Installation Information</b>	
Overall Weight	198kg
Heaviest Part	198kg
Largest Part	3.0m x 1.8m x 0.6m
Longest Part	3.0m
Concrete Required	0.2m <sup>3</sup>



KITEMARKED TO BS EN 1176