

Big City Plus - Antwerp Plus



-  **Option A**
Dark Blue & Orange (shown)
-  **Option B**
Purple & Yellow
-  **Option C**
All Green

Code – BC/ANT*2

Age

5-12 years

Materials

Stainless Steel

Nylon Steel Cored Rope

Compact Grade Laminate (CGL)

Various Plastic Mouldings

LLDPE Slide

A junior modular tower system comprising of:

- Square Tower (1.5m)
- Triangular Tower (1.1m)
- Slide (1.5m)
- Twisted Climbing Net (1.5m)
- Fireman's Pole (1.1m)
- Slide Climber (1.1m)
- Inclined Hoop Bars

Technical Information

Equipment Dimensions

Length / Width / Height **5.6m x 5.4m x 3.1m**

Surfacing and Area Required

Recommended Minimum Space L/W/H **9.5m x 8.6m x 4.3m**

Max Gradient of Ground **1 in 50**

Free Height of Fall **1.5m**

Impact Area **42.47m²**

Synthetic Area (i.e. EPDM / Wet Pour / Synthetic Grass etc.) **42.06m²**

Loosefill at 250mm (i.e. Bark / Cushionfall / Sand) **14m³**

GrassLok Tiles **59m²**

Installation Information

	SGF	SF (if different)
Installation Time	2 Persons 14 Hours	
Overall Weight	512kg	
Heaviest Part	37kg	
Largest Part	3.1m x 0.4m x 0.4m	
Longest Part	3.1m	
Concrete Required	0.72m³	1.09m³

Certified to ASTM F1487

[Click here for more information & downloads](#)



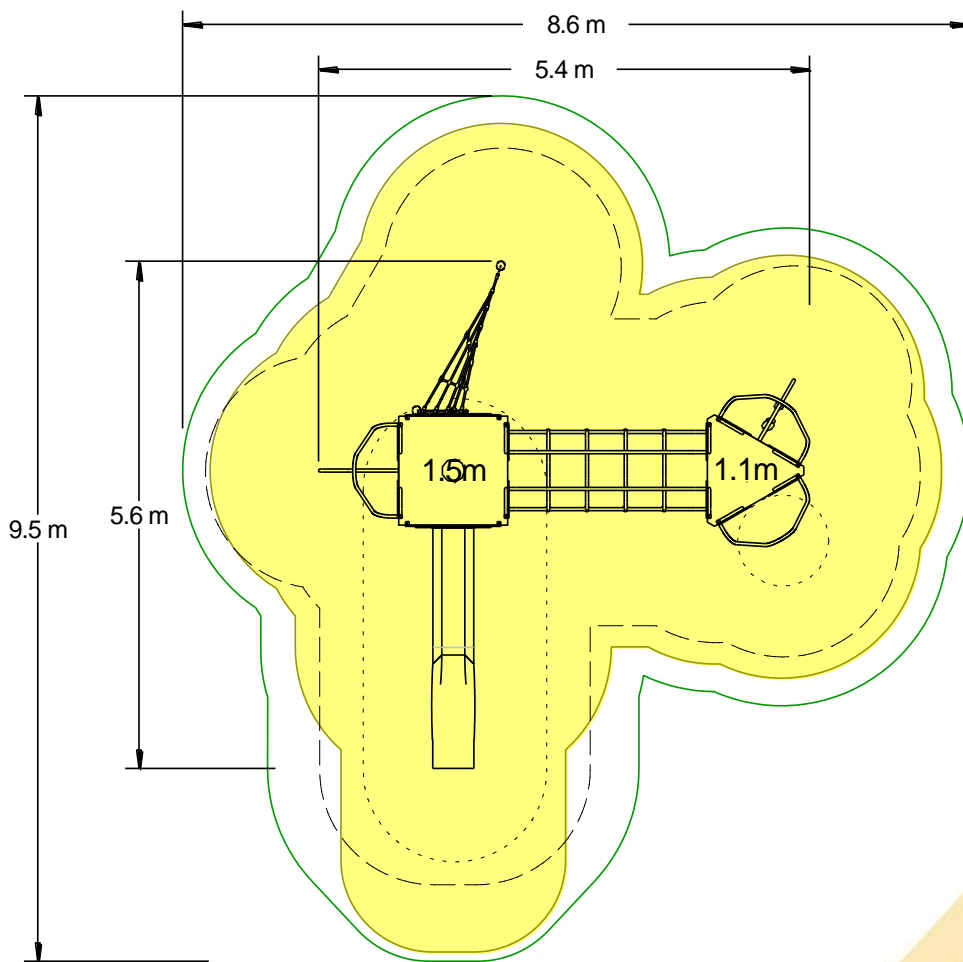
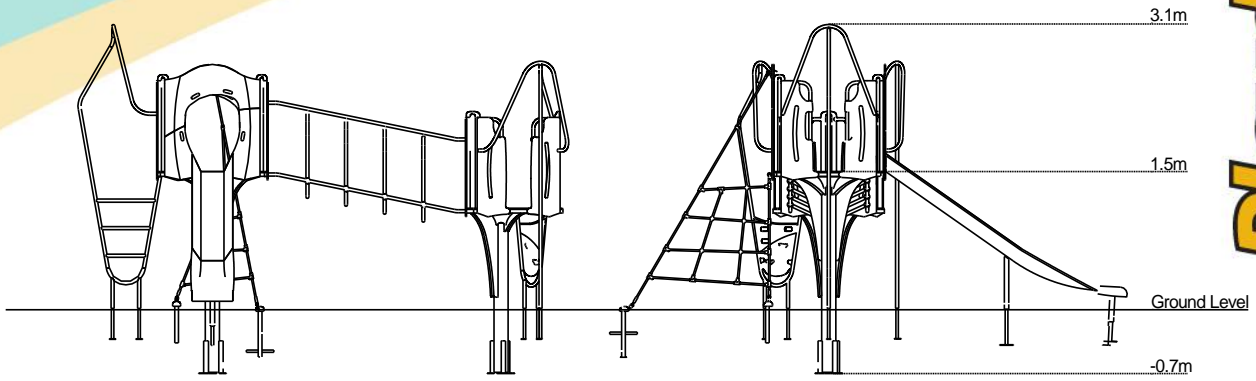

[Click here for more information & downloads](#)

